

Miniature Linear Guideway

MSC / MSD Type Stainless Steel Series

Content

1 Construction	02
2 Characteristics	02
3 Description of Specification	03
4 Accuracy	04
5 Preload	05
6 Dust Proof	05
7 The Shoulder Height and Corner Radius for Installation	07
8 Dimensional Tolerance of Mounting Surface	08
9 Rail Standard and Maximum Length	08
10 Dimensions	09

[Dimensions of MSC-M/MSD-LM](#)

[Dimensions of MSD-M/MSD-LM](#)

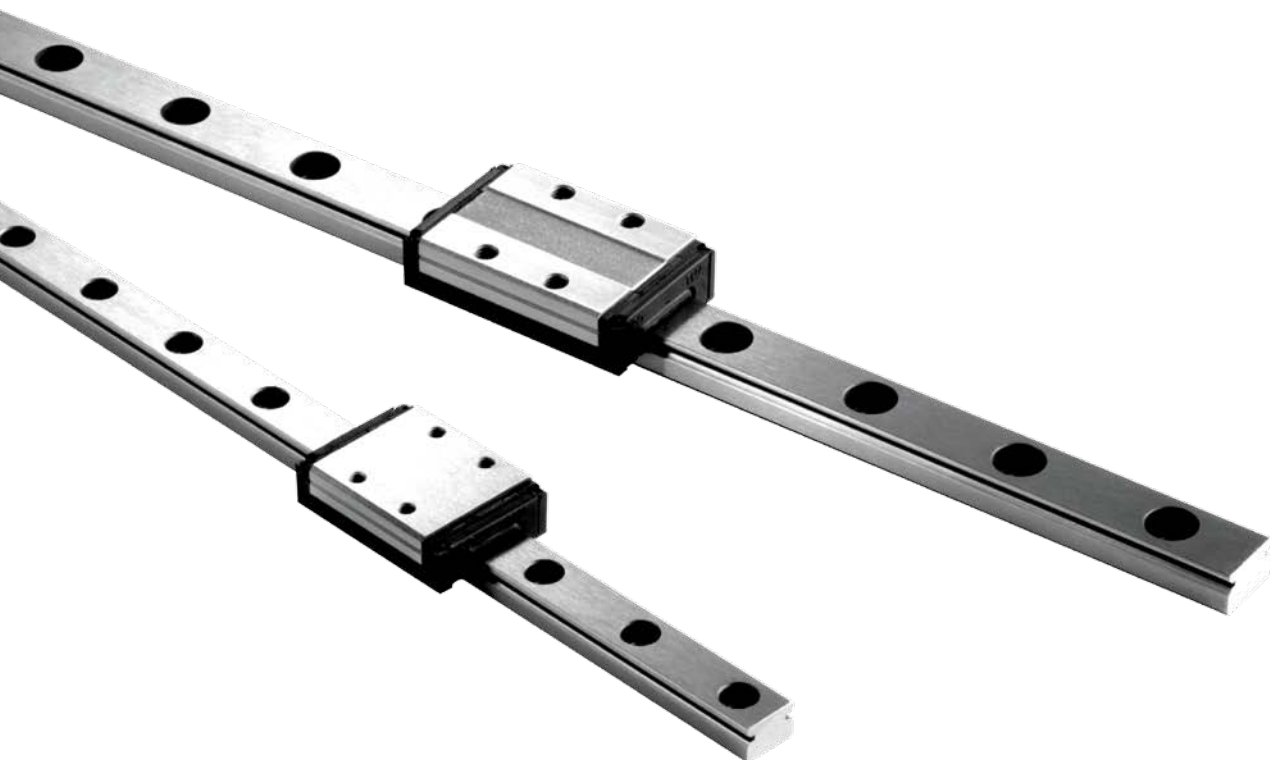

Miniature Linear Guideway MSC Standard / MSD Wide Type Stainless Steel Series

1 Construction

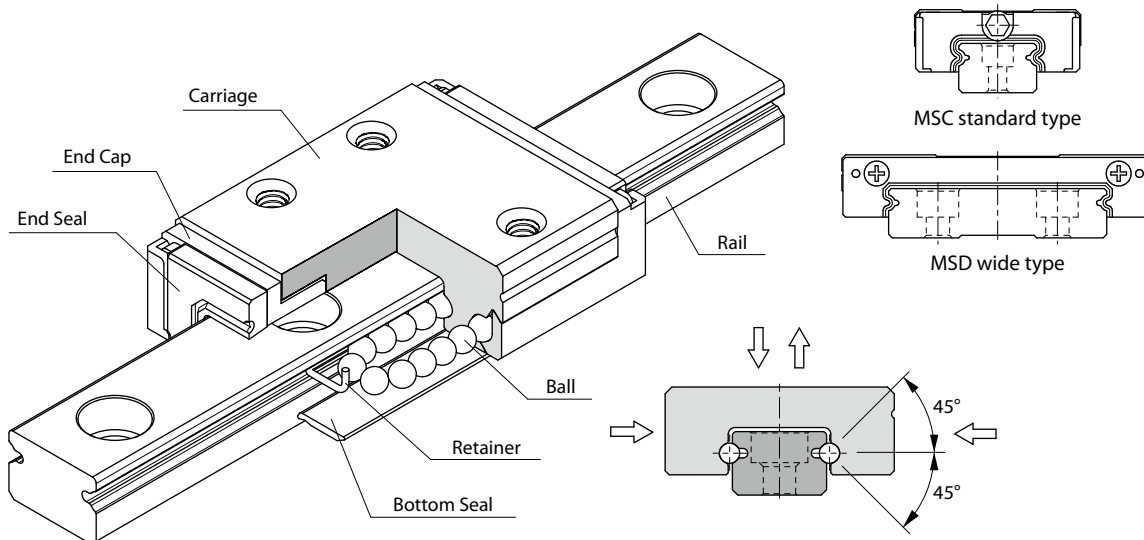

2 Characteristics

MSC standard type and MSD wide type stainless steel series are applied two rows with Gothic-arch groove and designed to contact angle of 45° which enables it to bear an equal load in radial, reversed radial and lateral directions. Furthermore, ultra compact and low friction resistance design is suit to compact equipment. The lubrication route makes the lubricant evenly distribute in each circulation loop. Therefore, the optimum lubrication can be achieved in any installation direction, and this promotes the performance in running accuracy, service life, and reliability.

Four-way Equal Load

The two trains of balls are allocated to a Gothic-arch groove contact angle at 45° , thus each train of balls can take up an equal rated load in all four directions.

Smooth Movement with Low Noise

The simplified design of circulating system with strengthened synthetic resin accessories makes the movement smooth and quiet.

Ultra Compact

The ultra compact design is suit to the compact application with limited in space.

with retained balls design

Design with ball retainer can prevent ball from dropping.

Interchangeability

For interchangeable type of linear guideway, the dimensional tolerances are strictly maintained within a reasonable range, and this has made the random matching of the same size of rails and carriages possible. Therefore, the similar preload and accuracy can be obtained even under the random matching condition. As a result of this advantage, the linear guideway can be stocked as standard parts, the installation and maintenance become more convenient. Moreover, this is also beneficial for shortening the delivery time.

3 Description of Specification

(1) Non-interchangeable Type

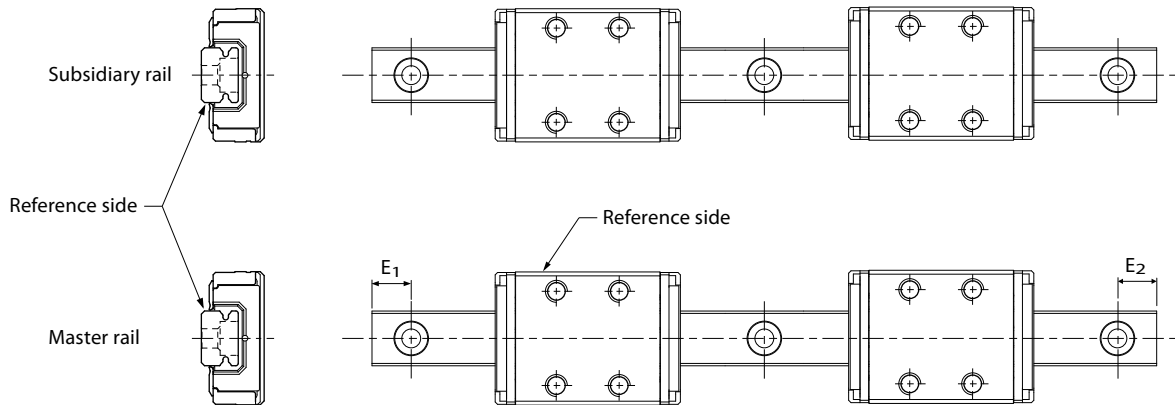
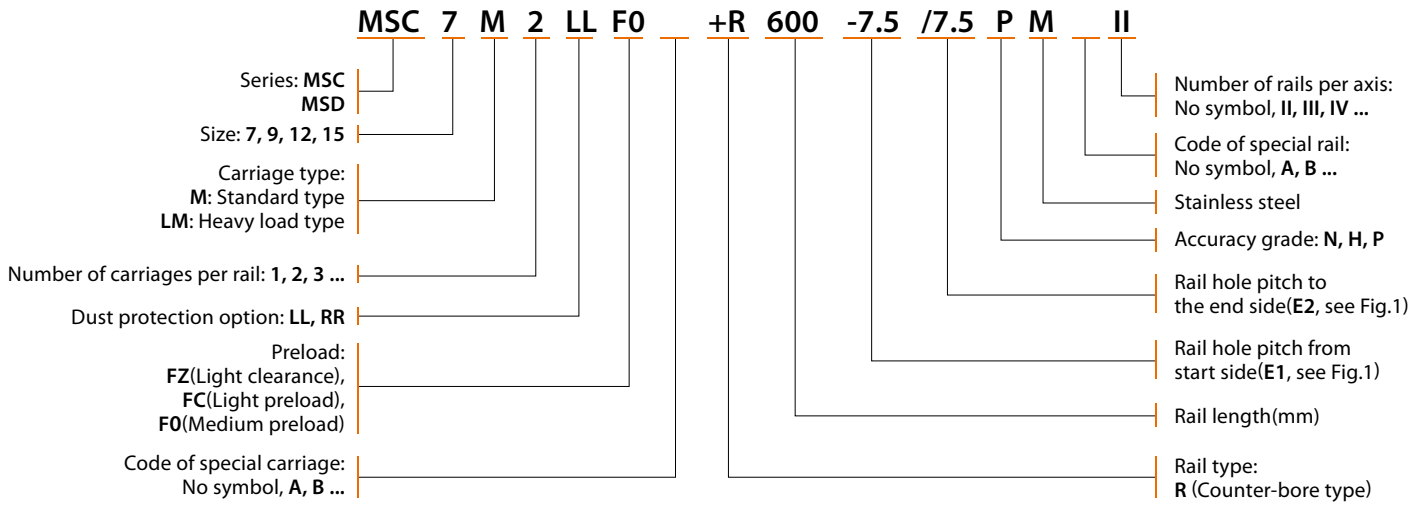
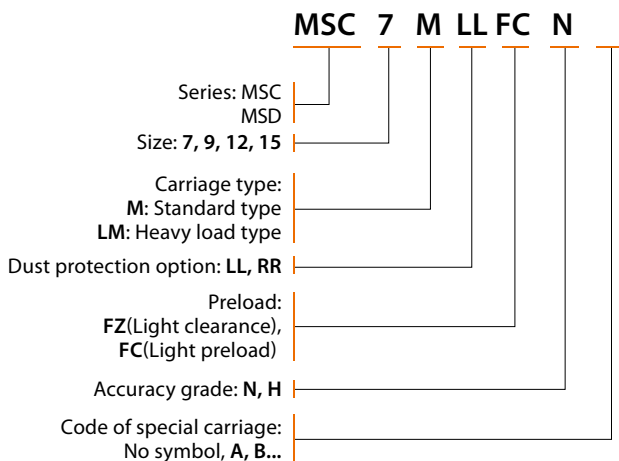

Fig.1

(2) Interchangeable Type

· Code of Carriage



· Code of Rail

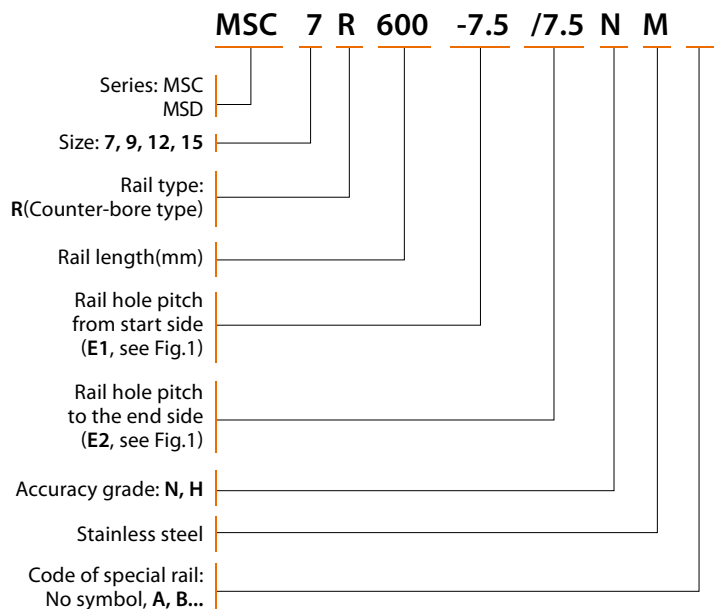

4 Accuracy

The accuracy of MSC & MSD series is divided into 3 classes, normal grade(N), high precision(H) and precision(P), as shown in Table 1.

Table 1

Model No.		Item	Accuracy Grade		
			Normal N	High H	Precision P
MSC 7 MSC 9 MSC 12 MSC 15	MSD 7 MSD 9 MSD 12 MSD 15	Tolerance for height H	±0.04	±0.02	±0.01
		Height difference (ΔH)	0.03	0.015	0.007
		Tolerance for distance W ₂	±0.04	±0.025	±0.015
		Difference in distance W ₂ (ΔW ₂)	0.03	0.02	0.01
		Running parallelism of surface C with surface A	Δ C (see Fig.2)		
		Running parallelism of surface D with surface B	Δ D (see Fig.2)		

Unit: mm

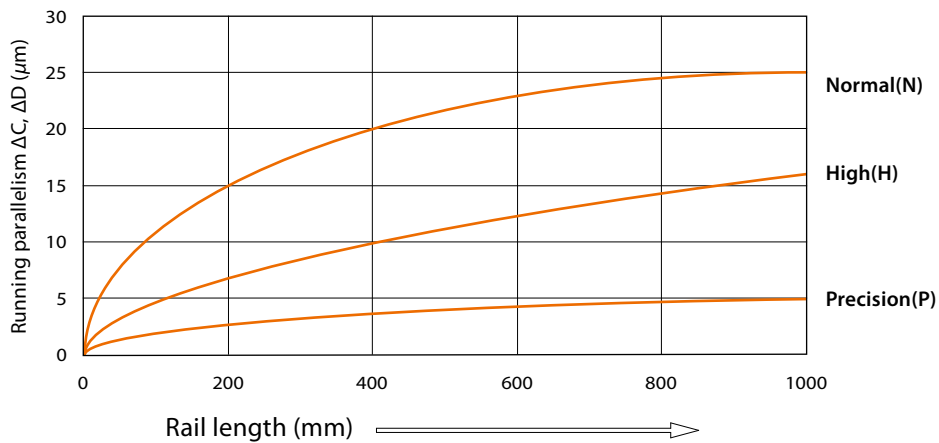
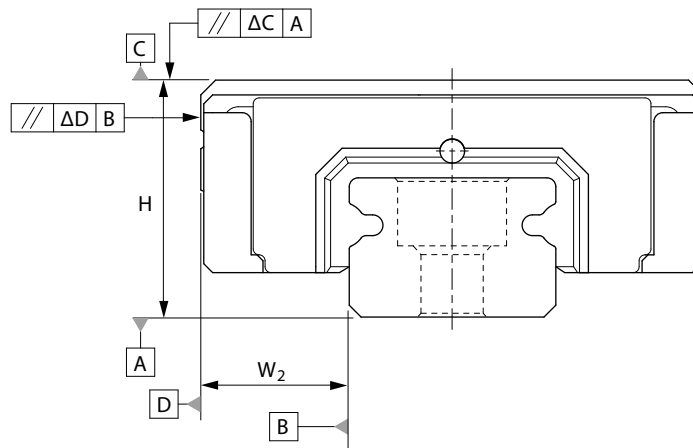

Fig.2 Running Parallelism of Carriage

5 Preload

The preload of MSC & MSD series provides three grades, clearance(FZ), light(FC), medium(F0), as shown in Table2.

■ Table 2

Preload grade

Preload grade	Symbol	Preload	Accuracy
Clearance	FZ	clearance 4~10 μm	N
Light	FC	0	N~P
Medium	F0	0.02C	N~P

* C in preload column means basic dynamic load rating.

6 Dust Proof

(1) Contamination protection

MSC & MSD series of linear guideway offers various kinds of dust protection accessory to keep the foreign matters from entering into the carriage.

· End seal

Monodirectional seal for low frictional resistance required.

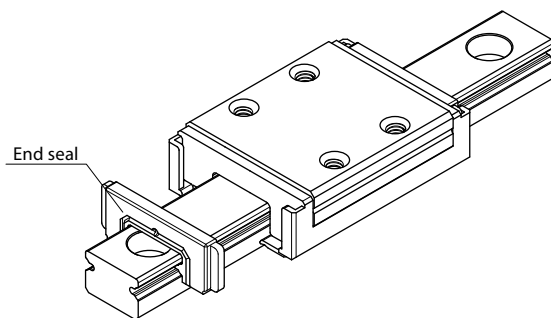

· Bottom Seal

Preventing the inclusion of foreign matters from bottom of carriage.

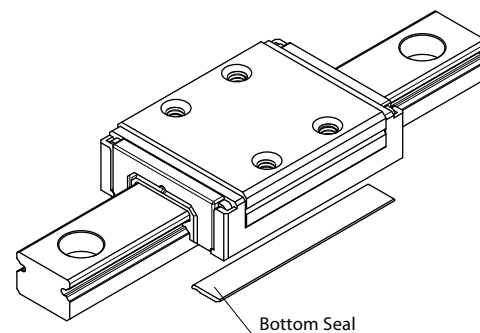

(2) Code of contamination protection

The codes for selection of dust protection accessory are shown as Table 3.

■ Table 3

Code of contamination protection

Code	Contamination protection
LL (Standard)	Low frictional end seal (both end)
RR	Low frictional end seal + Bottom seal

(3) Resistance value of Seal

The maximum resistance value of seals type LL when it is applied with grease is shown as Table 4.

■ Table 4

Seal resistance value

MSC Series		Unit: N	MSD Series		Unit: N
Model No.	Resistance		Model No.	Resistance	
MSC 7	0.08		MSD 7	0.4	
MSC 9	0.1		MSD 9	0.8	
MSC 12	0.4		MSD 12	1.1	
MSC 15	0.8		MSD 15	1.3	

(4) Caps for rail mounting hole

A special designed of cap is used to cover the bolt hole to prevent the foreign matters from entering the carriage.

The cap is mounted by using a plastic hammer with a flat pad placed on the top, until the top of cap is flush to the top surface of rail (see Fig. 3).

The dimension of caps for different sizes of rail is shown as Table 5.

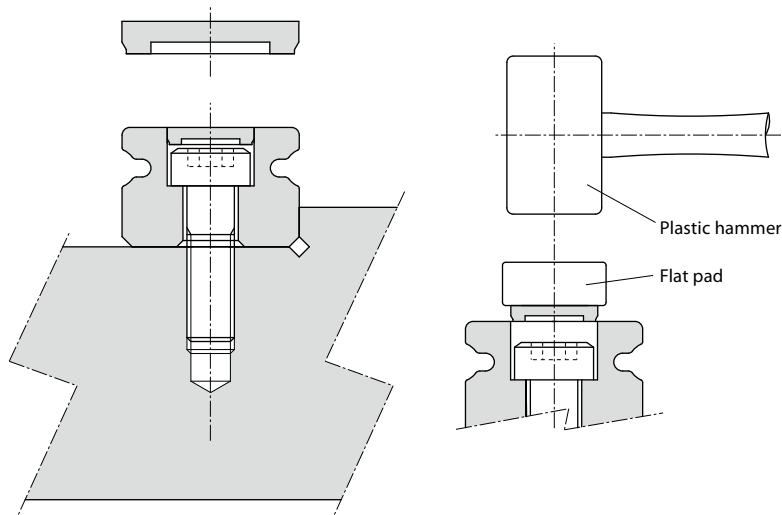

Fig.3 Cap for rail mounting hole

Table 5

Dimension of caps

Model No.	Code of Cap
MSC 12	M3C
MSC 15	M3C
MSD 9	M3C

* Not applicable to model MSC7, 9 and MSD7, 12, 15

7 The Shoulder Height and Corner Radius for Installation

The mounting surface of rails and carriages are machined precisely for aiding in positioning and assemble with high accuracy.

The shoulder height and corner radius providing enough mounting space for not to interfere with chamfers made on rails and carriages.

The dimensions of shoulder height and corner radius are shown as Table 6 and with bottom seal are shown as Table 7.

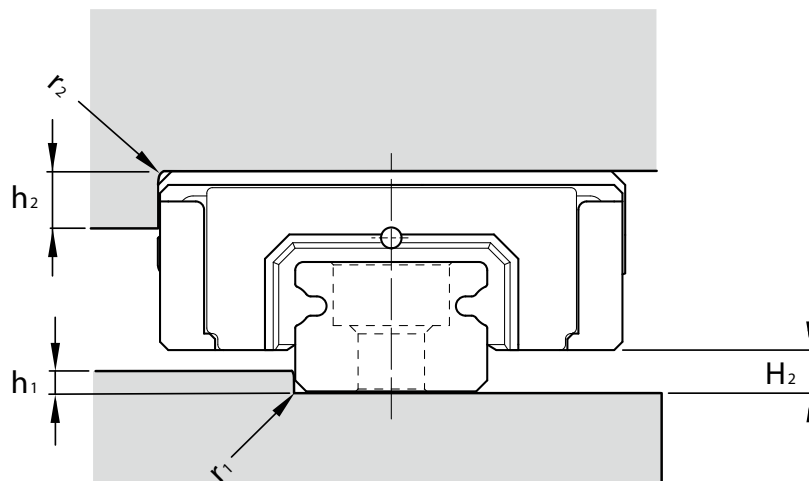

■ Table 6

Shoulder height and corner radius of mounting surface

MSC Series

Unit: mm

Model No.	r ₁ (max.)	r ₂ (max.)	h ₁	h ₂	H ₂
MSC 7	0.2	0.2	1.0	3	1.5
MSC 9	0.2	0.3	1.7	3	2.2
MSC 12	0.3	0.4	2.5	4	3.0
MSC 15	0.3	0.5	3.5	5	4.0

MSD Series

Unit: mm

Model No.	r ₁ (max.)	r ₂ (max.)	h ₁	h ₂	H ₂
MSD 7	0.2	0.2	1.5	3	2.0
MSD 9	0.2	0.3	3.2	3	3.7
MSD 12	0.3	0.4	3.5	4	4.0
MSD 15	0.3	0.5	3.5	5	4.0

■ Table 7

Shoulder height and corner radius of mounting surface with bottom seal

MSC Series

Unit: mm

Model No.	h ₁	H ₂
MSC 7	0.9	0.9
MSC 9	1.6	1.6
MSC 12	2.4	2.4
MSC 15	3.4	3.4

MSD Series

Unit: mm

Model No.	h ₁	H ₂
MSD 7	1.0	1.5
MSD 9	2.7	3.2
MSD 12	3.0	3.5
MSD 15	3.0	3.5

8 Dimensional Tolerance of Mounting Surface

The tolerances of parallelism between two axes are shown as below.

The parallel deviation between two axes (e1)

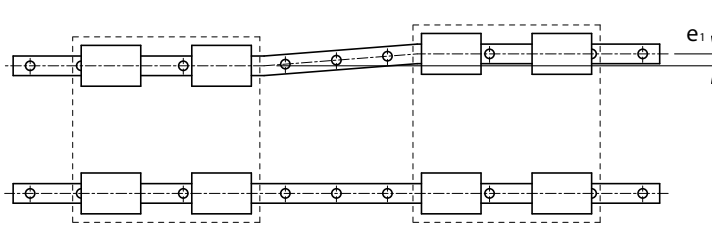

Table 8

Parallel deviation (e1)

Unit: μm

Model No.	Preload Grade		
	FZ	FC	F0
MSC 7 MSD 7	12	3	3
MSC 9 MSD 9	15	4	3
MSC 12 MSD 12	20	9	5
MSC 15 MSD 15	25	10	6

Level difference between two axes (e2)

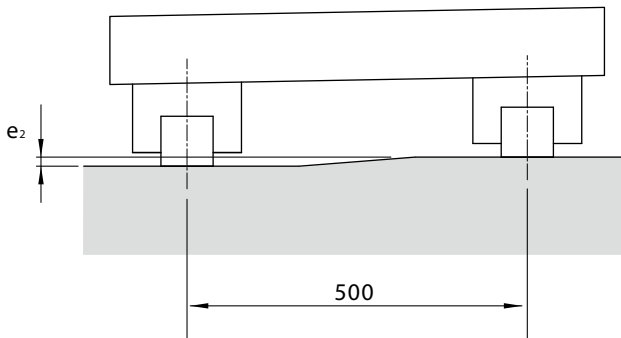

Table 9

Level difference between two axes (e2)

Unit: μm

Model No.	Preload Grade		
	FZ	FC	F0
MSC 7 MSD 7	160	25	6
MSC 9 MSD 9	250	35	6
MSC 12 MSD 12	300	50	12
MSC 15 MSD 15	350	60	20

* The permissible values in table are applicable when the span is 500mm wide.

9 Rail Standard and Maximum Length

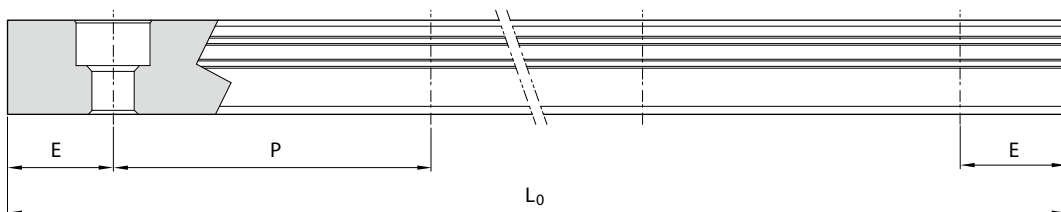

Unit: mm

Model No.	MSC 7	MSC 9	MSC 12	MSC 15	MSD 7	MSD 9	MSD 12	MSD 15
Standard Pitch (P)	15	20	25	40	30	30	40	40
Standard (E _{Std.})	5	7.5	10	15	10	10	15	15
Max. Length (L ₀ max.)	600	1000	1000	1000	1000	1000	1000	1000

10 Dimensions

Dimensions of MSC-M / MSC-LM

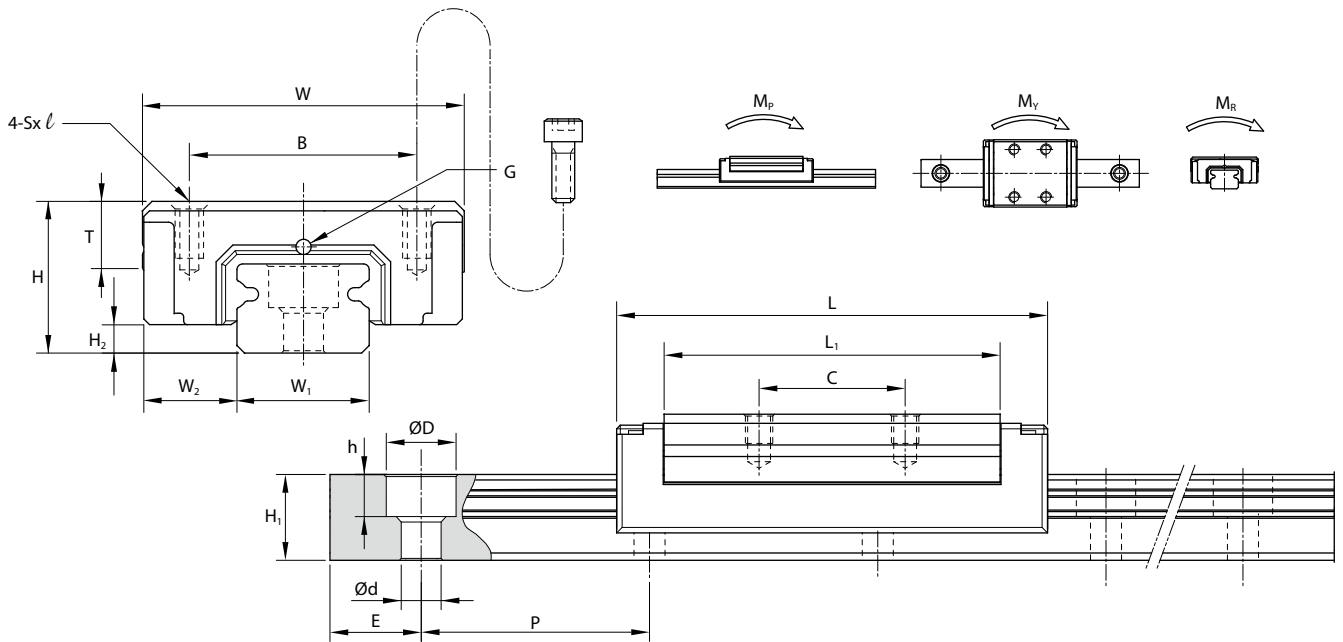

Unit: mm

Model No.	External dimension					Carriage dimension						
	Height H	Width W	Length L	W ₂	H ₂	B	C	S × l	L ₁	T	G	
MSC 7 M MSC 7 LM	8	17	23.6 33.1	5	1.5	12	8 13	M2 × 2.5	18.4 27.9	3.5	Ø0.8	
MSC 9 M MSC 9 LM	10	20	31.1 41.3	5.5	2.2	15	10 16	M3 × 3	25.8 36	4.5	Ø1	
MSC 12 M MSC 12 LM	13	27	34.6 47.6	7.5	3	20	15 20	M3 × 3.6	28 41	6	Ø1.5	
MSC 15 M MSC 15 LM	16	32	43.5 60.5	8.5	4	25	20 25	M3 × 4.2	36.1 53.1	7	G-M3	

Model No.	Rail dimension					Basic load rating		Static moment rating				Weight		
	Width W ₁	Height H ₁	Pitch P	E std.	D × h × d	Dynamic C kN	Static C ₀ kN	M _p N-m		M _y N-m		M _r N-m	Carriage g	Rail kg/m
								Single	Double	Single	Double			
MSC 7 M MSC 7 LM	7 ⁰ _{-0.05}	4.7	15	5	4.2 × 2.3 × 2.4	0.94 1.36	1.28 2.24	2.6 7.4	15.33 37.92	2.6 7.4	15.33 37.92	4.7 8.3	13 18	0.22
MSC 9 M MSC 9 LM	9 ⁰ _{-0.05}	5.5	20	7.5	6 × 3.3 × 3.5	1.71 2.52	2.24 3.92	6.1 17.4	33.46 84.63	6.1 17.4	33.46 84.63	10.8 18.8	29 39	0.33
MSC 12 M MSC 12 LM	12 ⁰ _{-0.05}	7.5	25	10	6 × 4.5 × 3.5	2.62 3.77	3.52 5.72	11.4 28.3	63.96 141.52	11.4 28.3	63.96 141.52	22.2 36.0	40 60	0.63
MSC 15 M MSC 15 LM	15 ⁰ _{-0.05}	9.5	40	15	6 × 4.5 × 3.5	4.52 6.47	5.70 9.26	24.7 61.0	132.17 295.87	24.7 61.0	132.17 295.87	44.4 72.2	71 100	1.02

* Single: Single carriage/ Double: Double carriages closely contacting with each other.

Dimensions of MSD-M / MSD-LM

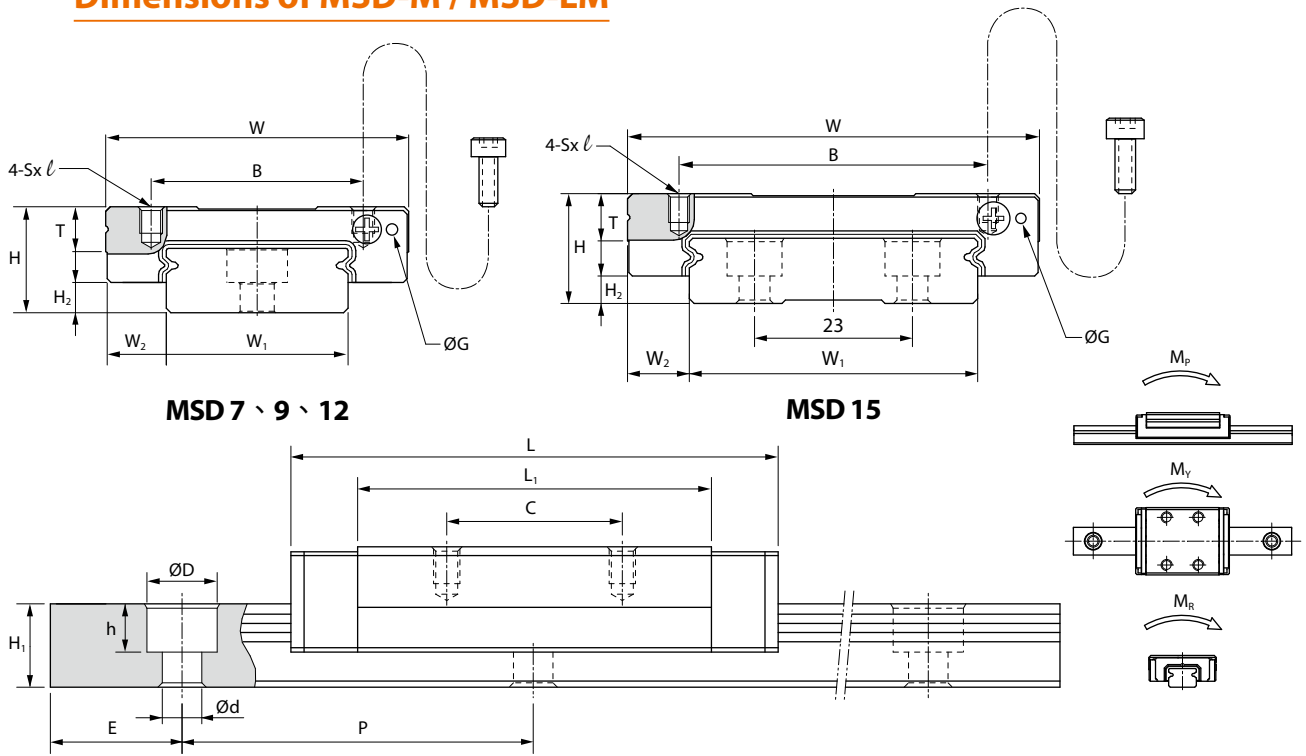

Unit: mm



Model No.	External dimension					Carriage dimension					
	Height H	Width W	Length L	W ₂	H ₂	B	C	S × l	L ₁	T	G
MSD 7 M MSD 7 LM	9	25	30.8 40.5	5.5	2	19	10 19	M3 × 3	20.6 30.3	3.9	Ø1.5
MSD 9 M MSD 9 LM	12	30	38.7 50.7	6	3.7	21 23	12 24	M3 × 3	27.1 39.1	5	Ø1.5
MSD 12 M MSD 12 LM	14	40	44.5 60	8	4	28	15 28	M3 × 4	31.0 46.5	6	Ø1.5
MSD 15 M MSD 15 LM	16	60	55.5 74.5	9	4	45	20 35	M4 × 4.5	40.3 59.3	7	Ø1.5

Model No.	Rail dimension					Basic load rating		Static moment rating				Weight		
	Width W ₁	Height H ₁	Pitch P	E std.	D × h × d	Dynamic C kN	Static C ₀ kN	M _p N-m		M _y N-m		M _r N-m	Carriage g	Rail kg/m
								Single*	Double*	Single*	Double*			
MSD 7 M MSD 7 LM	14 ⁰ _{-0.05}	5.2	30	10	6 × 3.2 × 3.5	1.51 2.04	2.46 3.79	6.6 17.5	39.0 84.0	6.6 17.5	39.0 84.0	17.7 27.3	23 31	0.55
MSD 9 M MSD 9 LM	18 ⁰ _{-0.05}	7	30	10	6 × 4.5 × 3.5	2.79 3.64	4.37 6.39	15.6 33.8	90.3 175.2	15.6 33.8	90.3 175.2	40.7 59.5	41 57	0.96
MSD 12 M MSD 12 LM	24 ⁰ _{-0.05}	8.5	40	15	8 × 4.5 × 4.5	4.05 5.28	6.20 9.06	26.3 57.0	151.5 294.4	26.3 57.0	151.5 294.4	76.3 116.6	70 101	1.55
MSD 15 M MSD 15 LM	42 ⁰ _{-0.05}	9.5	40	15	8 × 4.5 × 4.5	7.08 9.40	10.18 15.26	62.5 135.2	301.4 616.1	62.5 135.2	301.4 616.1	216.9 325.3	150 126	2.99

* Single: Single carriage/ Double: Double carriages closely contacting with each other.

PMI Linear Guideway Request Form

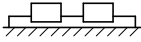
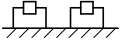
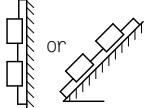
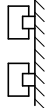
Date :

Customer Name :		Address :					
Tel :		Machine Type :					
Fax :		Drawing No. :					
Contact Person :							
Installation Direction							<input type="checkbox"/> Others
	<input type="checkbox"/> H type	<input type="checkbox"/> R type	<input type="checkbox"/> V type	<input type="checkbox"/> K type	<input type="checkbox"/> T type	<input type="checkbox"/> RV type	
Carriage Type	MSC - <input type="checkbox"/> M <input type="checkbox"/> LM MSD - <input type="checkbox"/> M <input type="checkbox"/> LM						
Size	<input type="checkbox"/> 7 <input type="checkbox"/> 9 <input type="checkbox"/> 12 <input type="checkbox"/> 15						
No. of Carriages	<input type="checkbox"/> 1 <input type="checkbox"/> 2 <input type="checkbox"/> 3 <input type="checkbox"/> 4 <input type="checkbox"/> Others :						
Dust Protection	<input type="checkbox"/> LL <input type="checkbox"/> RR						
Preload Grade	<input type="checkbox"/> FZ <input type="checkbox"/> FC <input type="checkbox"/> F0						
Rail Type	<input type="checkbox"/> Counter-bore (R type)						
Rail Length & Pitch	Length : E ₁ : E ₂ : E ₃ : E ₄ :						
Accuracy Grade	<input type="checkbox"/> N <input type="checkbox"/> H <input type="checkbox"/> P						
Rail per Axis	<input type="checkbox"/> 1 <input type="checkbox"/> 2 <input type="checkbox"/> 3 <input type="checkbox"/> Others :						
Full Code of Specification							
Required Quantity							

Reference surface

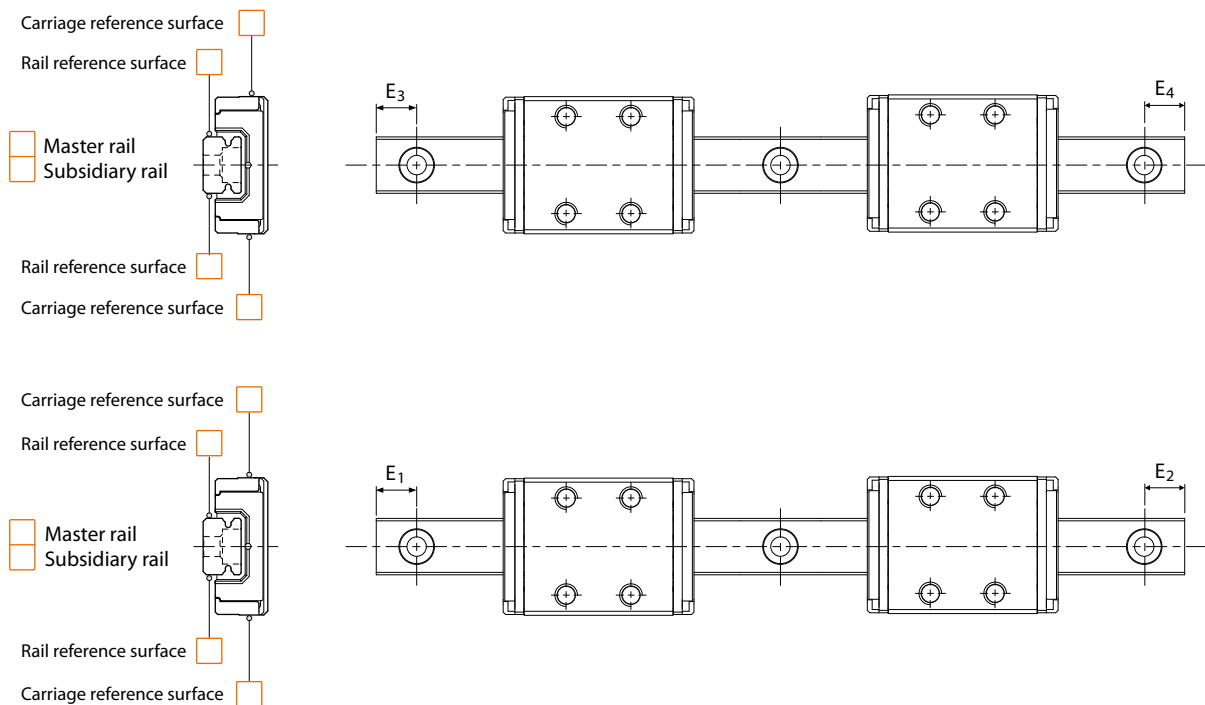

* Nonspecified cases followed by **PMI** standards. For other special requirements, please contact us.

The specifications in this catalogue are subject to change without notification.



PRECISION MOTION INDUSTRIES, INC.

No.71, Ln. 20, Dafu Rd., Shengang Dist.,
Taichung City 42946, Taiwan
TEL: +886-4-25282984 FAX: +886-4-25283392
E-mail: pmi.info@pmi-amt.com.tw