

Rolled BallScrews



Features:

1. Lower cost:

Since the manufacturing process for a rolled screw is less than that of a ground one. Hence the cost for rolled screw is lower.

2. Faster delivery:

There are standard ballnuts and screw shafts in stock. The delivery for rolled Ballscrews are made faster than the ground ones.

Lead accuracy:

PMI rolled Ballscrews are rolled by using German CNC rolling machine. It can well control the straightness; circleness and $e_{2\pi}$ of Ballscrews. The lead accuracy of PMI rolled Ballscrews can be as good as 0.018 mm/300 mm.

FSWW

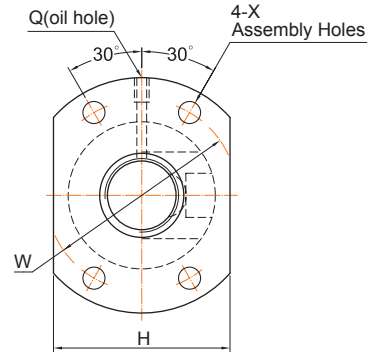

ITEM NO.	SCREW O.D. d	LEAD l	BALL DIA.	EFFECTIVE TURNS circuit Xrow	BASIC RATED LOAD (Kgf)		AXIAL PLAY			
					DYNAMIC (1x10 ⁶ REV.) Ca	STATIC Co		O.D. D	Length L	A
					1	14		4	2.381	3.5x1
2	14	5	3.175	2.5x1	515	990	0.10	40	40	57
3	20	5	3.175	2.5x1	625	1450	0.10	44	41	67
4	20	10	4.762	2.5x1	1100	2200	0.15	52	61	82
5	25	5	3.175	2.5x1	720	1830	0.10	50	41	73
6	25	5	3.175	2.5x2	1120	3710	0.10	50	56	73
7	25	10	6.350	2.5x1	1720	3590	0.20	60	69	96
8	25	10	6.350	2.5x2	3200	7170	0.20	60	97	96
9	32	10	6.350	2.5x1	1930	4680	0.20	67	69	103
10	32	10	6.350	2.5x2	3130	9410	0.20	67	97	103
11	40	10	6.350	2.5x2	3520	12000	0.20	76	100	116
12	50	10	6.350	2.5x2	3900	15000	0.20	88	101	128
13	50	10	6.350	3.5x2	4940	21000	0.20	88	126	128

Note:

Stiffness of nut:

Stiffness values listed above are derived from theoretical formula to the elastic deformation between thread grooves and balls while axial load is 30% dynamic load rating. Refer to P.15.

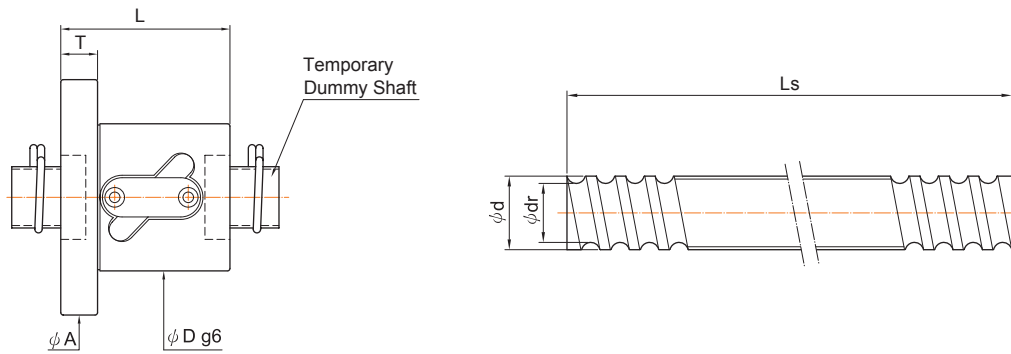

UNIT:mm

BALLNUT DIMENSION							SCREW SPINDLE		
Flange			Assembly Hole	Oil Hole	STIFFNESS	NUT MODEL	Root DIA.	Standard Screw Length	Screw Model
T	W	H	X	Q	kgf / μm	NO.	dr	Ls	NO.
10	40	-	4.5	M6x1P	15	9RFSWW1404-3.5P	12.00	500 1000	PS1404A
10	40	-	4.5	M6x1P	11	9RFSWW1405-2.5P	11.42	500 1000	PS1405A
10	55	52	5.5	M6x1P	15	9RFSWW2005-2.5P	17.42	500 1000 1500	PS2005A
12	67	64	6.6	M6x1P	16	9RFSWW2010-2.5P	16.23	500 1000 1500	PS2010A
11	61	56	6.6	M6x1P	18	9RFSWW2505-2.5P	22.42	1000 2000 2500	PS2505A
11	61	56	6.6	M6x1P	37	9RFSWW2505-5.0P	22.42	1000 2000 2500	PS2505A
15	78	72	9	M6x1P	21	9RFSWW2510-2.5P	20.05	1000 2000 2500	PS2510A
15	78	72	9	M6x1P	40	9RFSWW2510-5.0P	20.05	1000 2000 2500	PS2510A
15	85	78	9	M6x1P	25	9RFSWW3210-2.5P	27.05	1000 2000 2500	PS3210A
15	85	78	9	M6x1P	49	9RFSWW3210-5.0P	27.05	1000 2000 2500	PS3210A
17	96	88	11	M6x1P	59	9RFSWW4010-5.0P	35.05	2000 3000 3500	PS4010A
18	108	100	11	PT1/8"	72	9RFSWW5010-5.0P	45.05	2000 3000 3500	PS5010A
18	108	100	11	M6x1P	98	9RFSWW5010-7.0P	45.05	2000 3000 3500	PS5010A

FSVW

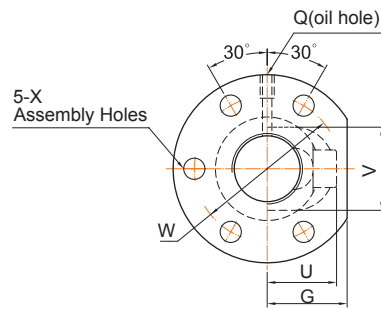

ITEM NO.	SCREW O.D. d	LEAD l	BALL DIA.	EFFECTIVE TURNS circuit xrow	BASIC RATED LOAD (Kgf)		AXIAL PLAY					
					DYNAMIC (1x10 ⁶ REV.) Ca	STATIC Co		O.D. D	Length L	Flange		
										A	T	W
1	14	4	2.381	3.5x1	500	1100	0.10	25	42	55	10	40
2	14	5	3.175	2.5x1	515	990	0.10	30	43	50	10	40
3	16	5	3.175	2.5x1	550	1140	0.10	34	43	54	10	44
4	20	5	3.175	2.5x1	625	1450	0.15	40	43	60	12	50
5	20	10	4.762	2.5x1	1100	2200	0.10	40	60	67	12	53
6	25	5	3.175	2.5x1	720	1830	0.20	42	45	71	12	57
7	25	5	3.175	2.5x2	1120	3710	0.20	42	60	71	12	57
8	25	10	6.350	2.5x1	1720	3590	0.20	44	68	79	15	62
9	25	10	6.350	2.5x2	3200	7170	0.20	44	98	79	15	62
10	32	10	6.350	2.5x1	1930	4680	0.20	55	72	97	18	75
11	32	10	6.350	2.5x2	3130	9410	0.20	55	101	97	18	75
12	40	10	6.350	3.5x2	4450	16800	0.20	65	123	114	20	90
13	50	10	6.350	3.5x2	4940	21000	0.20	80	125	138	22	110

Note:

Stiffness of nut:

Stiffness values listed above are derived from theoretical formula to the elastic deformation between thread grooves and balls while axial load is 30% dynamic load rating. Refer to P.15.

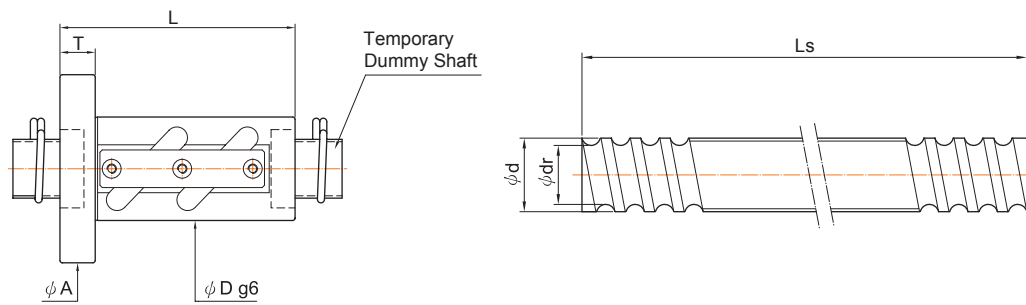

UNIT:mm

BALLNUT DIMENSION						SCREW SPINDLE			
G	Return tube		Assembly Hole X	Oil Hole Q	STIFFNESS kgf / μm	NUT MODEL NO.	Root DIA. dr	Standard Screw Length Ls	Screw Model NO.
	U	V							
19	19	21	4.5	M6x1P	15	9RFSVW1404-3.5P	12.00	500 1000	PS1404A
22	22	21	4.5	M6x1P	11	9RFSVW1405-2.5P	11.42	500 1000	PS1405A
24	20	22	4.5	M6x1P	13	9RFSVW1605-2.5P	13.42	500 1000 1500	PS1605A
28	28	27	4.5	M6x1P	15	9RFSVW2005-2.5P	17.42	500 1000 1500	PS2005A
30	30	30	6.6	M6x1P	16	9RFSVW2010-2.5P	16.23	500 1000 1500	PS2010A
28	28	32	6.6	M6x1P	18	9RFSVW2505-2.5P	22.42	1000 2000 2500	PS2505A
28	28	32	6.6	M6x1P	37	9RFSVW2505-5.0P	22.42	1000 2000 2500	PS2505A
34	34	37	9.0	M6x1P	21	9RFSVW2510-2.5P	20.05	1000 2000 2500	PS2510A
34	34	37	9.0	M6x1P	40	9RFSVW2510-5.0P	20.05	1000 2000 2500	PS2510A
39	39	44	11	M6x1P	25	9RFSVW3210-2.5P	27.05	1000 2000 2500	PS3210A
39	39	44	11	M6x1P	49	9RFSVW3210-5.0P	27.05	1000 2000 2500	PS3210A
44	44	52	14	M6x1P	81	9RFSVW4010-7.0P	35.05	2000 3000 3500	PS4010A
52	52	62	18	M6x1P	98	9RFSVW5010-7.0P	45.05	2000 3000 3500	PS5010A

RSVW

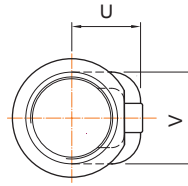

ITEM NO.	SCREW O.D. d	LEAD l	BALL DIA.	EFFECTIVE TURNS circuit Xrow	BASIC RATED LOAD (Kgf)		AXIAL PLAY		
					DYNAMIC (1x10 ⁶ REV.) Ca	STATIC Co		O.D. D	Length L
1	14	4	2.381	3.5x1	500	1100	0.10	25	42
2	14	5	3.175	2.5x1	515	990	0.10	30	43
3	20	5	3.175	2.5x1	625	1450	0.10	40	43
4	25	5	3.175	2.5x1	720	1830	0.10	42	48
5	25	5	3.175	2.5x2	1120	3710	0.10	42	63
6	25	10	6.350	2.5x1	1720	3590	0.20	44	68
7	25	10	6.350	2.5x2	3200	7170	0.20	44	98
8	32	10	6.350	2.5x1	1930	4680	0.20	55	72
9	32	10	6.350	2.5x2	3130	9410	0.20	55	101
10	40	10	6.350	3.5x2	4450	16800	0.20	65	128
11	50	10	6.350	3.5x2	4940	21000	0.20	80	143

Note:

Stiffness of nut:

Stiffness values listed above are derived from theoretical formula to the elastic deformation between thread grooves and balls while axial load is 30% dynamic load rating. Refer to P.15.

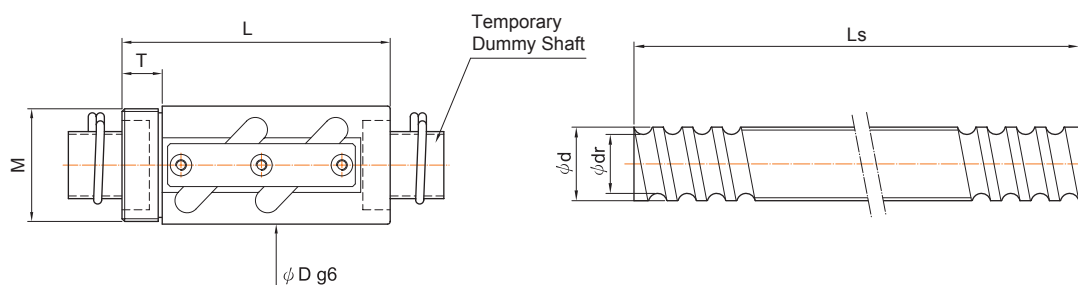

UNIT:mm

BALLNUT DIMENSION					SCREW SPINDLE				
M	Flange		Return Tube		STIFFNESS kgf / μm	NUT MODEL NO.	Root DIA. dr	Standard Screw Length Ls	Screw Model NO.
	T	U	V						
M24x1.0P	10	19	21	15	9RRSVW1404-3.5P	12.00	500 1000	PS1404A	
M26x1.5P	10	22	21	11	9RRSVW1405-2.5P	11.42	500 1000	PS1405A	
M36x1.5P	12	28	27	15	9RRSVW2005-2.5P	17.42	500 1000 1500	PS2005A	
M40x1.5P	15	28	32	18	9RRSVW2505-2.5P	22.42	1000 2000 2500	PS2505A	
M40x1.5P	15	28	32	37	9RRSVW2505-5.0P	22.42	1000 2000 2500	PS2505A	
M42x1.5P	15	34	37	21	9RRSVW2510-2.5P	20.05	1000 2000 2500	PS2510A	
M42x1.5P	15	34	37	40	9RRSVW2510-5.0P	20.05	1000 2000 2500	PS2510A	
M50x1.5P	18	39	44	25	9RRSVW3210-2.5P	27.05	1000 2000 2500	PS3210A	
M50x1.5P	18	39	44	49	9RRSVW3210-5.0P	27.05	1000 2000 2500	PS3210A	
M60x2.0P	25	44	52	81	9RRSVW4010-7.0P	35.05	2000 3000 3500	PS4010A	
M75x2.0P	40	52	62	98	9RRSVW5010-7.0P	45.05	2000 3000 3500	PS5010A	

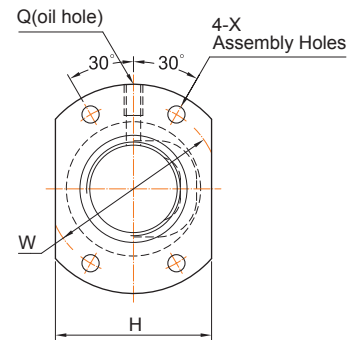

ITEM NO.	SCREW O.D. d	LEAD l	BALL DIA.	EFFECTIVE TURNS circuit Xrow	BASIC RATED LOAD (Kgf)		AXIAL PLAY			
					DYNAMIC (1x10 ⁶ REV.) Ca	STATIC Co		O.D. D	Length L	A
1	8	2.5	2.000	2.5x1	220	260	0.10	22	34	41
2	10	2.5	2.000	2.5x1	250	320	0.10	24	34	44
3	10	4	2.381	2.5x1	350	600	0.10	26	41	47
4	12	2.5	2.000	2.5x1	270	350	0.10	26	34	47
5	12	5	2.000	2.5x1	270	350	0.10	26	40	47
6	14	4	2.381	3.5x1	545	1100	0.10	31	40	50
7	14	5	3.175	2.5x1	535	990	0.10	32	40	50
8	16	5	3.175	2.5x1	570	1130	0.10	34	40	54
9	20	4	2.381	2.5x1	415	850	0.10	40	41	59
10	20	5	3.175	2.5x1	650	1450	0.10	40	40	59
11	25	4	2.381	2.5x1	450	980	0.10	43	41	67
12	25	5	3.175	2.5x1	720	1800	0.10	43	40	67

Note:

Stiffness of nut:

Stiffness values listed above are derived from theoretical formula to the elastic deformation between thread grooves and balls while axial load is 30% dynamic load rating. Refer to P.15.

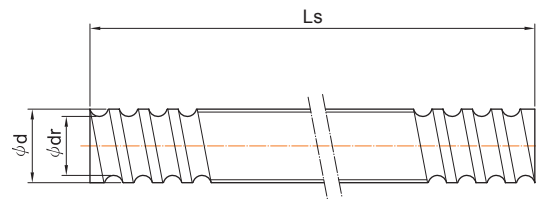
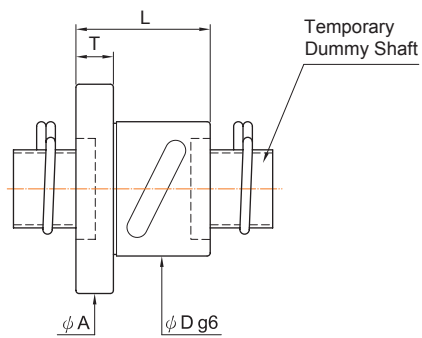

UNIT:mm

BALLNUT DIMENSION						SCREW SPINDLE			
Flange			Assembly Hole X	Oil Hole Q	STIFFNESS kgf / μm	NUT MODEL NO.	Root DIA. dr	Standard Screw Length Ls	Screw Model NO.
T	W	H							
8	31	26	4.5	M6x1P	5.0	9RFSBW0825-2.5P	6.40	200 300	PS0825A
8	34	28	4.5	M6x1P	6.5	9RFSBW1025-2.5P	8.40	200 300	PS1025A
10	37	30	4.5	M6x1P	7.5	9RFSBW1004-2.5P	8.00	300 500	PS1004A
10	37	30	4.5	M6x1P	8.2	9RFSBW1225-2.5P	10.40	500 1000	PS1225A
10	37	30	4.5	M6x1P	8.2	9RFSBW1205-2.5P	10.40	500 1000	PS1205A
10	40	37	4.5	M6x1P	15	9RFSBW1404-3.5P	12.00	500 1000	PS1404A
10	40	38	4.5	M6x1P	11	9RFSBW1405-2.5P	11.42	500 1000	PS1405A
10	44	40	4.5	M6x1P	13	9RFSBW1605-2.5P	13.42	500 1000	PS1605A
10	50	46	4.5	M6x1P	14	9RFSBW2004-2.5P	18.00	500 1000 1500	PS2004A
10	50	46	4.5	M6x1P	16	9RFSBW2005-2.5P	17.42	500 1000 1500	PS2005A
10	55	50	4.5	M6x1P	17	9RFSBW2504-2.5P	23.00	500 1000 1500	PS2504A
10	55	50	5.5	M6x1P	18	9RFSBW2505-2.5P	22.42	500 1000 1500	PS2505A

FSIW

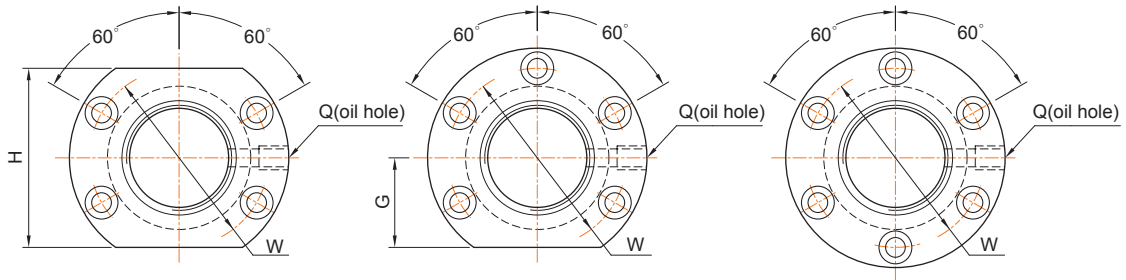

ITEM NO.	SCREW O.D. d	LEAD l	BALL DIA.	EFFECTIVE TURNS	BASIC RATED LOAD (Kgf)		AXIAL PLAY						
					DYNAMIC (1x10 ⁶ REV.) Ca	STATIC Co		O.D. D	Length L	Flange			
										A	T	W	G
1	14	4	2.381	4	400	890	0.10	26	47	46	10	36	-
2	16	5	3.175	3	570	1030	0.10	30	42	49	10	39	20
3	20	5	3.175	4	830	1890	0.10	34	53	57	12	45	20
4	25	5	3.175	4	940	2420	0.10	40	53	63.5	12	51	22
5	32	5	3.175	4	1050	3390	0.10	48	53	73.5	12	60	30
6	32	10	6.350	4	2510	5880	0.20	54	90	88	16	70	34
7	40	5	3.175	4	1180	4390	0.10	55	56	88.5	16	72	29
8	40	10	6.350	4	2630	7860	0.20	64	93	106	18	84	43
9	50	10	6.350	4	2770	10290	0.20	74	93	116	18	94	42

Note:

Stiffness of nut:

Stiffness values listed above are derived from theoretical formula to the elastic deformation between thread grooves and balls while axial load is 30% dynamic load rating. Refer to P.15.

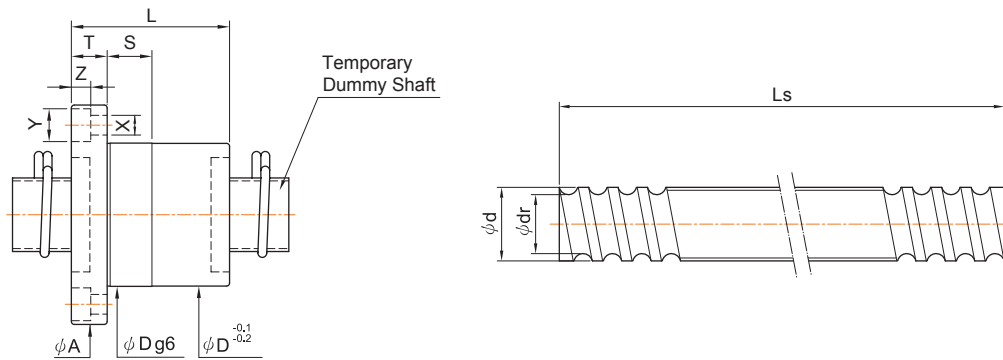

UNIT:mm

BALLNUT DIMENSION							SCREW SPINDLE			
H	Fit S	Assembly Hole			Oil Hole Q	STIFFNESS kgf / μm	NUT MODEL NO.	Root DIA. dr	Standard Screw Length Ls	Screw Model NO.
		X	Y	Z						
-	10	4.5	8	4.5	M6x1P	18	9RFSIW1404-4.0P	12.00	500 1000	PS1404A
40	10	4.5	-	-	M6x1P	17	9RFSIW1605-3.0P	13.42	500 1000 1500	PS1605A
40	12	5.5	9.5	5.5	M6x1P	21	9RFSIW2005-4.0P	17.42	500 1000 1500	PS2005A
44	15	5.5	9.5	5.5	M6x1P	26	9RFSIW2505-4.0P	22.42	1000 2000 2500	PS2505A
60	15	6.6	11	6.5	M8x1P	32	9RFSIW3205-4.0P	29.42	1000 2000 2500	PS3205A
68	15	9	14	8.5	M8x1P	34	9RFSIW3210-4.0P	27.05	1000 2000 2500	PS3210A
58	15	9	14	8.5	M8x1P	38	9RFSIW4005-4.0P	37.42	2000 3000 3500	PS4005A
86	20	11	17.5	11	M8x1P	41	9RFSIW4010-4.0P	35.05	2000 3000 3500	PS4010A
84	20	11	17.5	11	M8x1P	50	9RFSIW5010-4.0P	45.05	2000 3000 3500	PS5010A

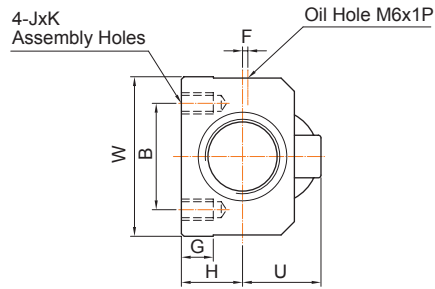

ITEM NO.	SCREW O.D. d	LEAD l	BALL DIA.	EFFECTIVE TURNS circuit Xrow	BASIC RATED LOAD (Kgf)		AXIAL PLAY					
					DYNAMIC (1x10 ⁶ REV.) Ca	STATIC Co		Length L	Width W	Height H	Assembly Hole	
											A	B
1	14	4	2.381	3.5x1	545	1110	0.10	35	34	13	22	26
2	14	5	3.175	2.5x1	535	990	0.10	35	34	13	22	26
3	16	5	3.175	2.5x1	590	1210	0.10	35	42	16	22	32
4	20	5	3.175	2.5x1	650	1450	0.10	35	48	17	22	35
5	20	10	4.762	2.5x1	1100	2220	0.15	58	48	18	35	35
6	25	5	3.175	2.5x1	720	1850	0.10	35	60	20	22	40
7	25	10	6.350	2.5x2	3240	7170	0.20	94	60	23	60	40
8	28	6	3.175	2.5x2	1380	4140	0.10	67	60	22	40	40
9	32	10	6.350	2.5x1	2010	4700	0.20	64	70	26	45	50
10	32	10	6.350	2.5x2	3640	9410	0.20	94	70	26	60	50

Note:

Stiffness of nut:

Stiffness values listed above are derived from theoretical formula to the elastic deformation between thread grooves and balls while axial load is 30% dynamic load rating. Refer to P.15.

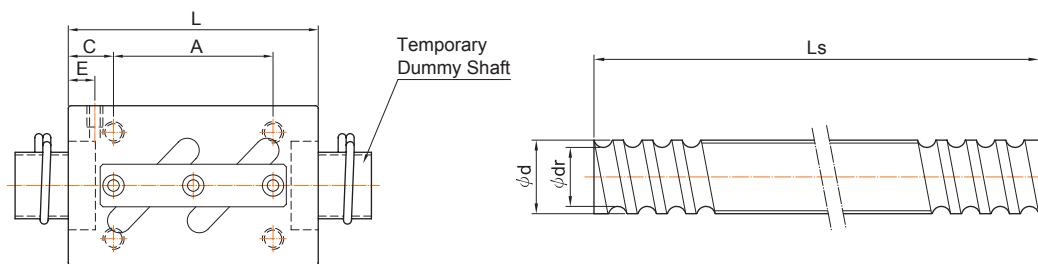

UNIT:mm

BALLNUT DIMENSION							SCREW SPINDLE			
C	JxK	Position of Oil Hole		Height from Reference Surface		STIFFNESS kgf / μm	NUT MODEL NO.	Root DIA. dr	Standard Screw Length Ls	Screw Model NO.
		E	F	G	U					
6.5	M4x7	6	2	6	18	15	9RSSVW1404-3.5P	12.00	500 1000	PS1404A
6.5	M4x7	6	2	6	18	11	9RSSVW1405-2.5P	11.42	500 1000	PS1405A
6.5	M5x8	6	2	8	21	13	9RSSVW1605-2.5P	13.42	500 1000 1500	PS1605A
6.5	M6x10	6	3	9.15	22	15	9RSSVW2005-2.5P	17.42	500 1000 1500	PS2005A
11.5	M6x10	10	2	9.5	30	16	9RSSVW2010-2.5P	16.23	500 1000 1500	PS2010A
6.5	M8x12	7	5	9.5	25	18	9RSSVW2505-2.5P	22.42	1000 2000 2500	PS2505A
17	M8x12	10	-	10	30	40	9RSSVW2510-5.0P	20.05	1000 2000 2500	PS2510A
13.5	M8x12	8	5	10	27	39	9RSSVW2806-5.0P	25.42	1000 2000 2500	PS2806A
9.5	M8x12	10	-	12	36	25	9RSSVW3210-2.5P	27.05	1000 2000 2500	PS3210A
17	M8x12	10	-	12	36	49	9RSSVW3210-5.0P	27.05	1000 2000 2500	PS3210A

FSKW

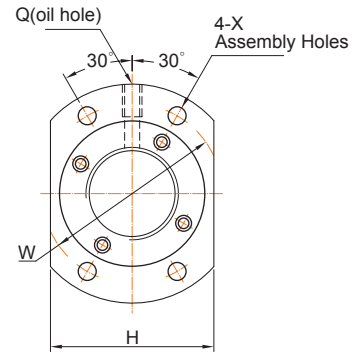

ITEM NO.	SCREW O.D. d	LEAD l	BALL DIA.	EFFECTIVE TURNS circuit Xrow	BASIC RATED LOAD (Kgf)		AXIAL PLAY			
					DYNAMIC (1x10 ⁶ REV.) Ca	STATIC Co		O.D. D	Length L	A
1	15	10	3.175	2.8x2	1000	2570	0.10	34	44	57
2	16	16	3.175	1.8x1	330	640	0.10	32	38	53
3	20	20	3.175	1.8x2	780	2280	0.10	39	52	62
4	25	25	3.969	1.8x2	1230	3570	0.10	47	64	74
5	25	25	3.969	1.8x4	2230	7140	0.10	47	64	74
6	32	32	4.762	1.8x2	1760	5500	0.15	58	78	92
7	32	32	4.762	1.8x4	3200	11000	0.15	58	78	92
8	40	40	6.350	1.8x2	2870	9170	0.20	73	95	114
9	40	40	6.350	1.8x4	5220	18340	0.20	73	95	114

Note:

Stiffness of nut:

Stiffness values listed above are derived from theoretical formula to the elastic deformation between thread grooves and balls while axial load is 30% dynamic load rating. Refer to P.15.

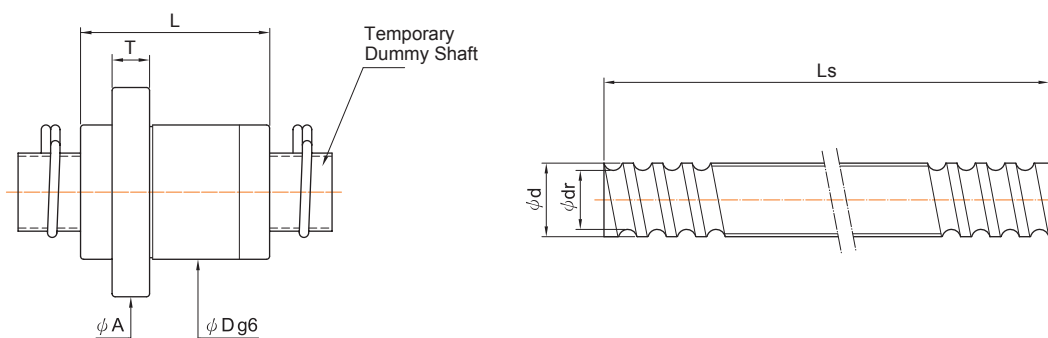

UNIT:mm

BALLNUT DIMENSION						SCREW SPINDLE			
Flange			Assembly Hole X	Oil Hole Q	STIFFNESS kgf / μm	NUT MODEL NO.	Root DIA. dr	Standard Screw Length Ls	Screw Model NO.
T	W	H							
10	45	40	5.5	M6x1P	26	9RFSKW1510-5.6P	12.42	500 1000	PS1510A
10	42	38	4.5	M6x1P	9	9RFSKW1616-1.8P	13.42	500 1000 1500	PS1616A
10	50	46	5.5	M6x1P	21	9RFSKW2020-3.6P	17.42	500 1000 1500	PS2020A
12	60	56	6.6	M6x1P	27	9RFSKW2525-3.6P	21.73	1000 2000 2500	PS2525A
12	60	56	6.6	M6x1P	52	9RFSKW2525-7.2P	21.73	1000 2000 2500	PS2525A
15	74	68	9	M6x1P	33	9RFSKW3232-3.6P	28.23	1000 2000 2500	PS3232A
15	74	68	9	M6x1P	65	9RFSKW3232-7.2P	28.23	1000 2000 2500	PS3232A
17	93	84	11	M6x1P	42	9RFSKW4040-3.6P	35.05	2000 3000 3500	PS4040A
17	93	84	11	M6x1P	81	9RFSKW4040-7.2P	35.05	2000 3000 3500	PS4040A